

BRC07533HMC

Rev.B Mar.-2026

描述 / Descriptions

SOT23-3 塑封封装 低压差线性稳压器。

Low dropout linear regulator in a SOT23-3 Plastic Package.

特征 / Features

- ◆ 低静态工作电流：2uA
- ◆ 输出电流：200mA
- ◆ 低压差：450mV@100mA($V_{OUT}=3.3V$)
- ◆ 高精度： $\pm 2\%$
- ◆ 高电源抑制比：70dB@1kHz
- ◆ 低输出噪声：90uV_{RMS} (10Hz~100kHz)
- ◆ 出色的输入线性和输出负载瞬态响应
- ◆ 内置电流限制，短路保护
- ◆ 过热保护
- ◆ 无卤产品

用途 / Applications

用于各类电源设备，通信设备，音频和视频设备。

For use in power equipment, Communication equipment, Audio and video equipment.

内部等效电路 / Equivalent Circuit

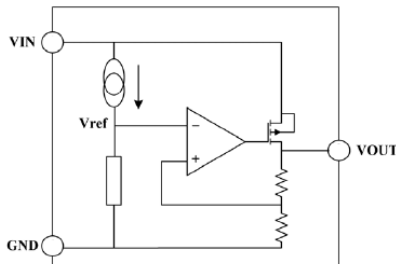

引脚排列 / Pinning

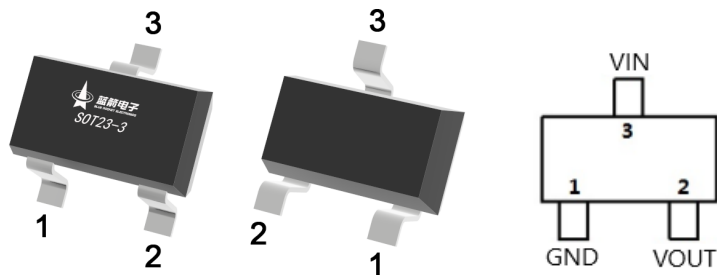

引脚	名称	功能	引脚	名称	功能
1	GND	电源地	3	VIN	电压输入端
2	VOUT	电压输出端			

印章代码 / Marking

见印章说明。See Marking Instructions.

极限参数 / Absolute Maximum Ratings(Ta=25°C)

参数	符号	数值	单位
输入电压	V _{IN}	-0.3 to 40	V
输出电流	I _{OUT}	200	mA
耗散功率	P _D	0.6	W
储存温度	T _{stg}	-40 to +125	°C
工作温度	T _A	-40 to +85	°C
管脚焊接温度 (10s)	T _{sold}	260	°C
防静电等级	HBM	2	kV
	MM	200	V

注：如果器件运行条件超过上述各项条件最大额定值，可能对器件造成永久性损坏。上述参数仅是运行条件的极大值，我们不建议器件在该规范范围外运行。如果器件长时间工作在绝对最大极限条件下，其稳定性可能会受到影响。

Notes: If the device operating conditions over the maximum rating of the above-mentioned conditions, may cause permanent damage to the device. The above parameters is only part of the operating conditions the maximum, we do not recommend the device running outside the scope of this specification. If the device to work long hours under the condition of absolute maximum limit, its stability may be affected.

电性能参数 / Electrical Characteristics(T_A=25 °C , V_{IN}=V_{OUT}+2V, C_{IN}=C_{OUT}=1uF, unless otherwise specified)

参数	符号	测试条件	最小值	典型值	最大值	单位
输入电压	V _{IN}				36	V
输出电压 ⁽¹⁾	V _{OUT (E)}	I _{OUT} =10mA	3.234	3.3	3.366	V
输入输出压差 ⁽²⁾	V _{dif}	I _{OUT} =100mA V _{OUT} =3.3V		450		mV
静态工作电流	I _{SS}	I _{OUT} =0mA		2	5	uA
负载调整率	ΔV _{load}	V _{IN} =V _{OUT (S)} +2V 1mA≤I _{OUT} ≤200mA		20	50	mV
线性调整率	ΔV _{line}	I _{OUT} =10mA V _{OUT (S)} +2V≤V _{IN} ≤ 36V		10	50	mV
输出电压温度系数	ΔV _{OUT} / (ΔT _A *V _{OUT})	I _{OUT} =10mA -40°C≤T _A ≤85°C		50		ppm/°C
输出电流限制	I _{LIM}	V _{OUT} = 0.5 x V _{OUT(Normal)} , V _{IN} = 5.3V		300		mA
输出短路电流	I _{SHORT}	V _{OUT} =V _{SS}		100		mA

电性能参数 / Electrical Characteristics($T_A=25^{\circ}\text{C}$, $V_{IN}=V_{OUT}+2\text{V}$, $C_{IN}=C_{OUT}=1\mu\text{F}$, unless otherwise specified)

参数	符号	测试条件	最小值	典型值	最大值	单位
电源纹波抑制比	PSRR	$I_{OUT}=50\text{mA}$, $f=100\text{Hz}$		80		dB
		$I_{OUT}=50\text{mA}$, $f=1\text{kHz}$		70		
		$I_{OUT}=50\text{mA}$, $f=10\text{kHz}$		60		
		$I_{OUT}=50\text{mA}$, $f=100\text{kHz}$		50		
输出噪声电压	V_{ON}	$\text{BW}=10\text{Hz to } 100\text{kHz}$		90		μV_{RMS}

(1) $V_{OUT(E)}$ 为实际输出电压, $V_{OUT(S)}$ 为设定的标称输出电压

(2) 输入输出电压差的定义: 固定负载条件下, 输出电压 V_{OUT} , 缓慢下降输入电压, 直至输出电压降低到 $V_{OUT} \cdot 98\%$ 时, 输入电压和输出电压的差值。

电参数曲线图 / Electrical Characteristic Curve

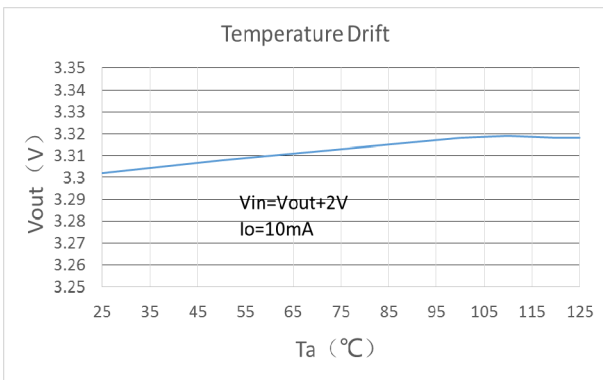
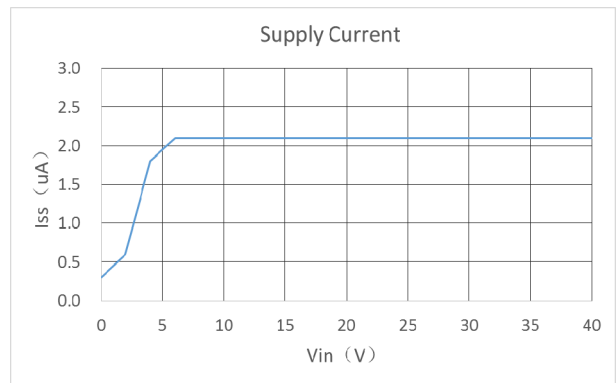
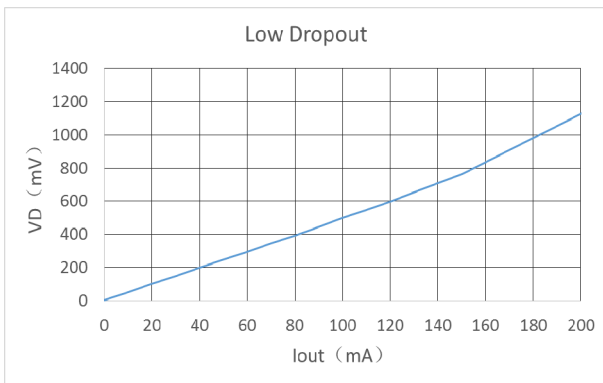
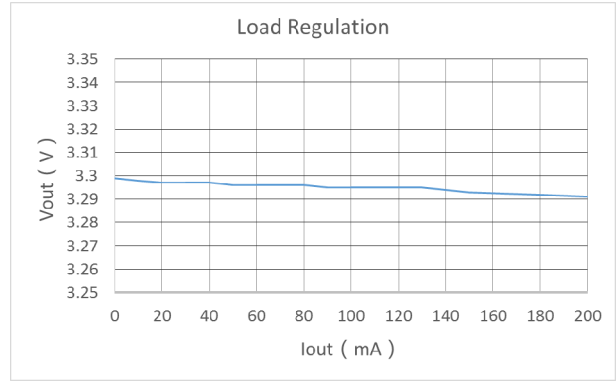
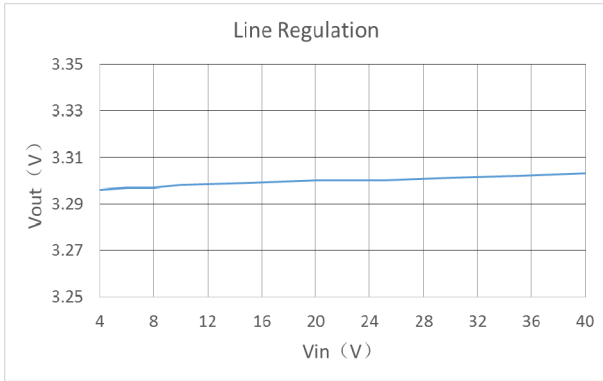

典型应用电路 / Typical Application Circuit

基本应用 / Basic Application

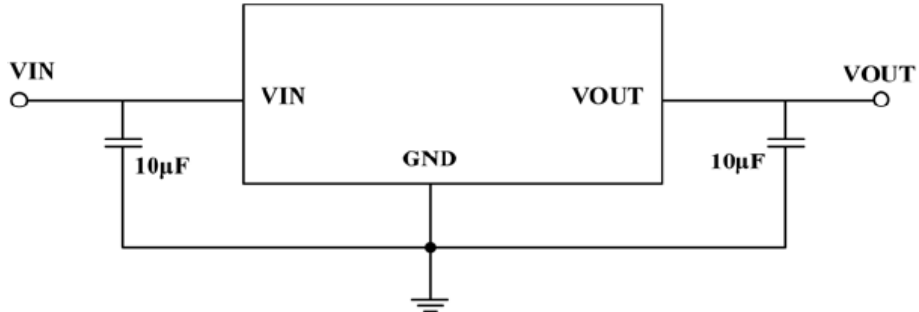

输出大电流电压调节器 / High Output Current Voltage Regulator

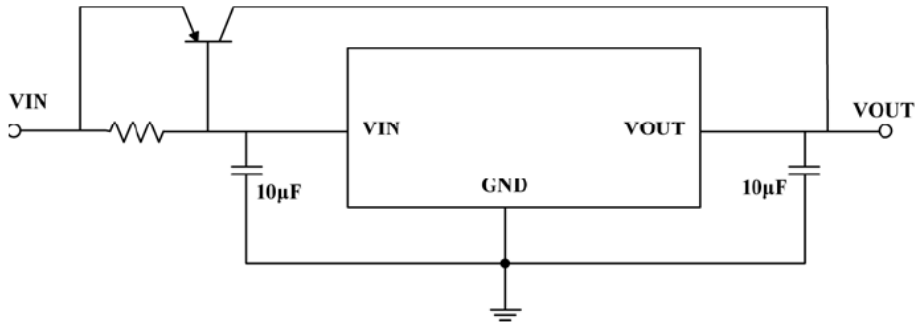

短路保护应用 / Short-Circuit Protection

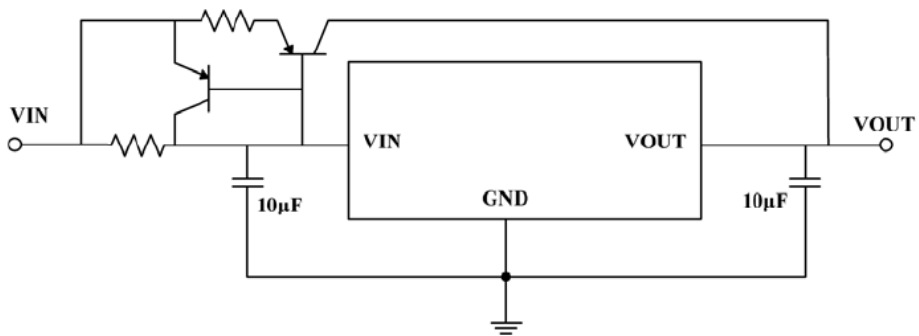

典型应用电路 / Typical Application Circuit

输出高电压电路 / Circuit for Increasing Output Voltage

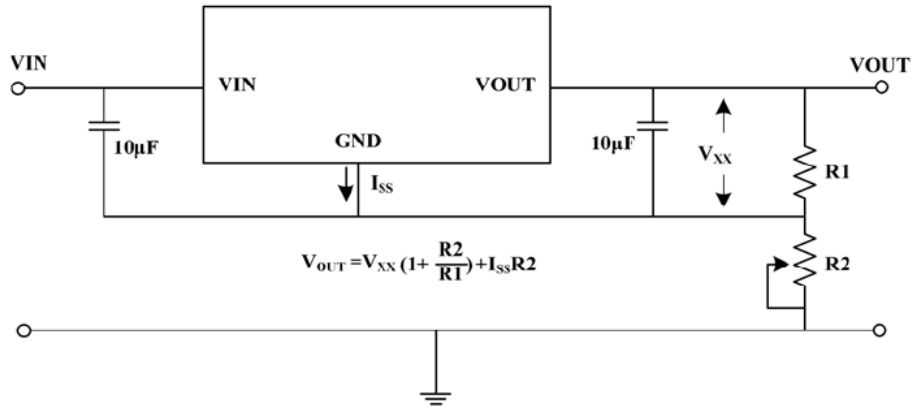

输出电流调节电路 / Constant Current Regulator

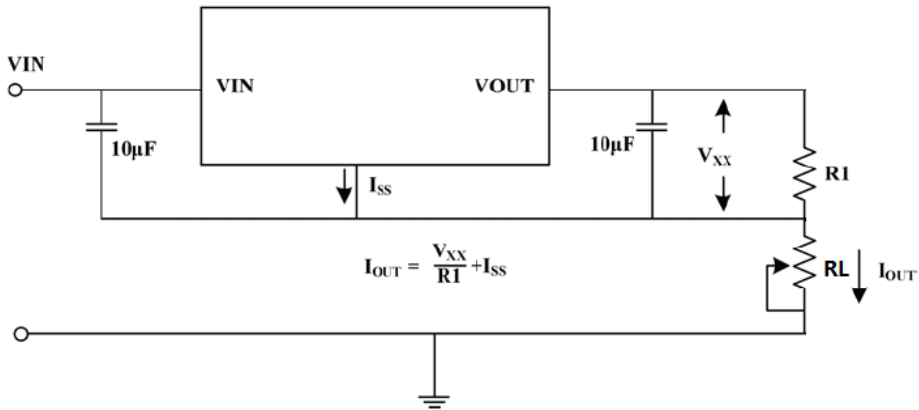

双输出电路 / Double Output Circuit

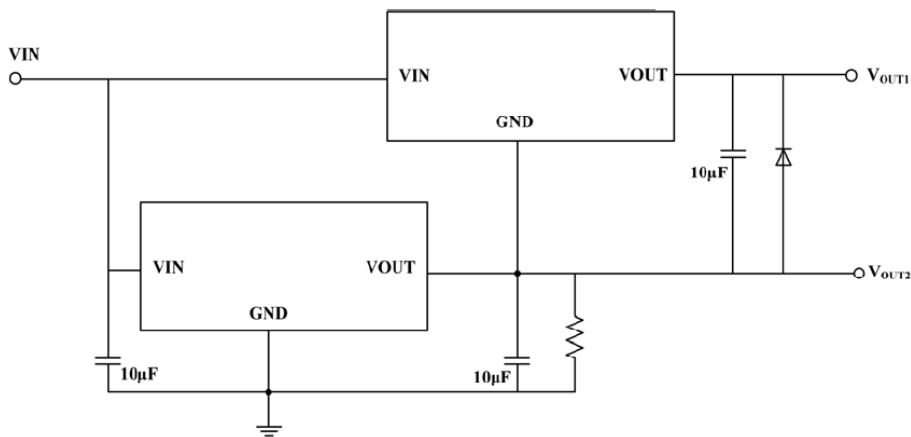

外形尺寸图 / Package Dimensions

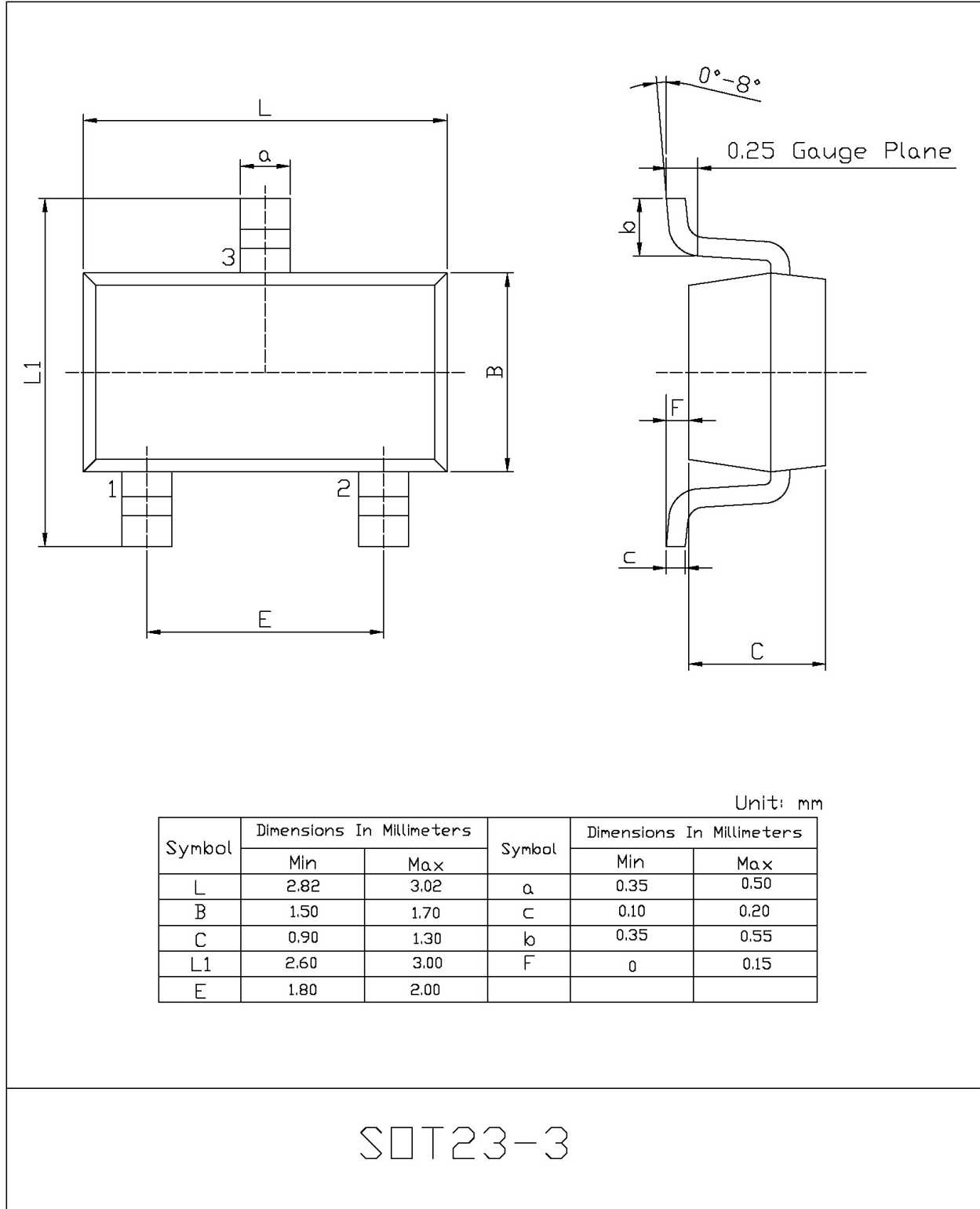

印章说明 / Marking Instructions

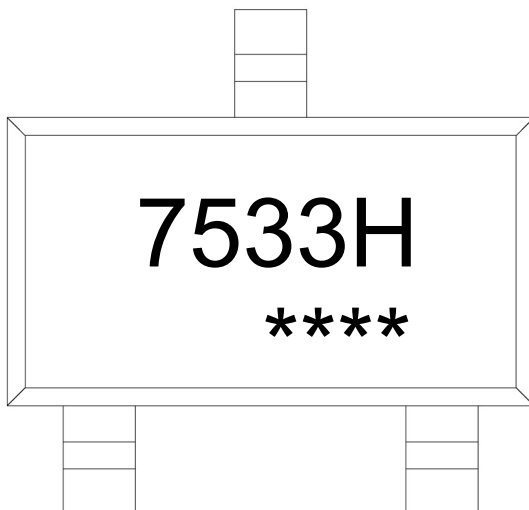

说明：

7533H： 为型号代码

****： 为生产批号代码，随生产批号变化

Note:

7533H: Product Type Code

****: Lot No. Code, code change with Lot No

回流焊温度曲线图(无铅) / Temperature Profile for IR Reflow Soldering(Pb-Free)

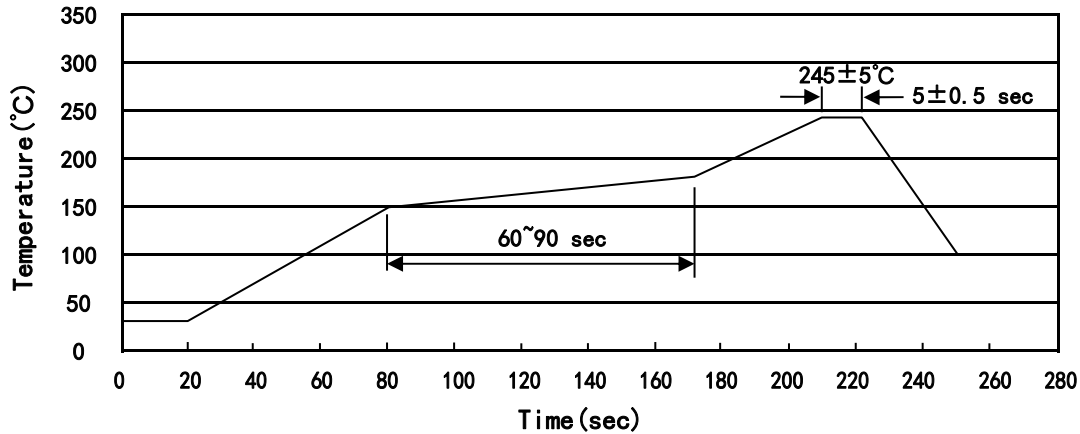

说明：

- 1、预热温度 150~180°C，时间 60~90sec;
- 2、峰值温度 245±5°C，时间持续为 5±0.5sec;
- 3、焊接制程冷却速度为 2~10°C/sec.

Note:

- 1.Preheating:150~180°C, Time:60~90sec.
- 2.Peak Temp.:245±5°C, Duration:5±0.5sec.
3. Cooling Speed: 2~10°C/sec.

耐焊接热试验条件 / Resistance to Soldering Heat Test Conditions

温度：260±5°C

时间：10±1 sec.

Temp.:260±5°C

Time:10±1 sec

包装规格 / Packaging SPEC.

卷盘包装 / REEL

Package Type 封装形式	Units 包装数量					Dimension 包装尺寸 (unit: mm ³)		
	Units/Reel 只/卷盘	Reels/Inner Box 卷盘/盒	Units/Inner Box 只/盒	Inner Boxes/Outer Box 盒/箱	Units/Outer Box 只/箱	Reel	Inner Box 盒	Outer Box 箱
SOT23-3	3,000	10	30,000	4	120,000	7" ×8	210×205×205	445×435×230

使用说明 / Notices